



**Fast Tessellated
Rendering on Fermi
GF100**

Hot3D @ HPG 2010

Tim Purcell



Outline



- **DX10 state of the art**
- **DX11 tessellation**
- **Fermi GF100 architecture**
- **Results**
- **Demo**

State of the Art: DX10 pipeline

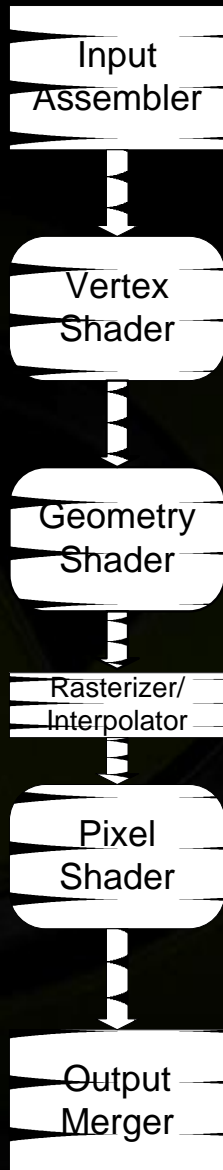

- **Pixels are meticulously shaded**

State of the Art: DX10 pipeline



Image from Far Cry® 2,
courtesy of Ubisoft

- **Pixels are meticulously shaded, but geometric detail is modest**

Tessellation in DirectX 11



- **Hull shader**
 - **Computes the tessellation factor**
 - **Runs pre-expansion**
 - **Explicitly parallel across control points**

From input assembly

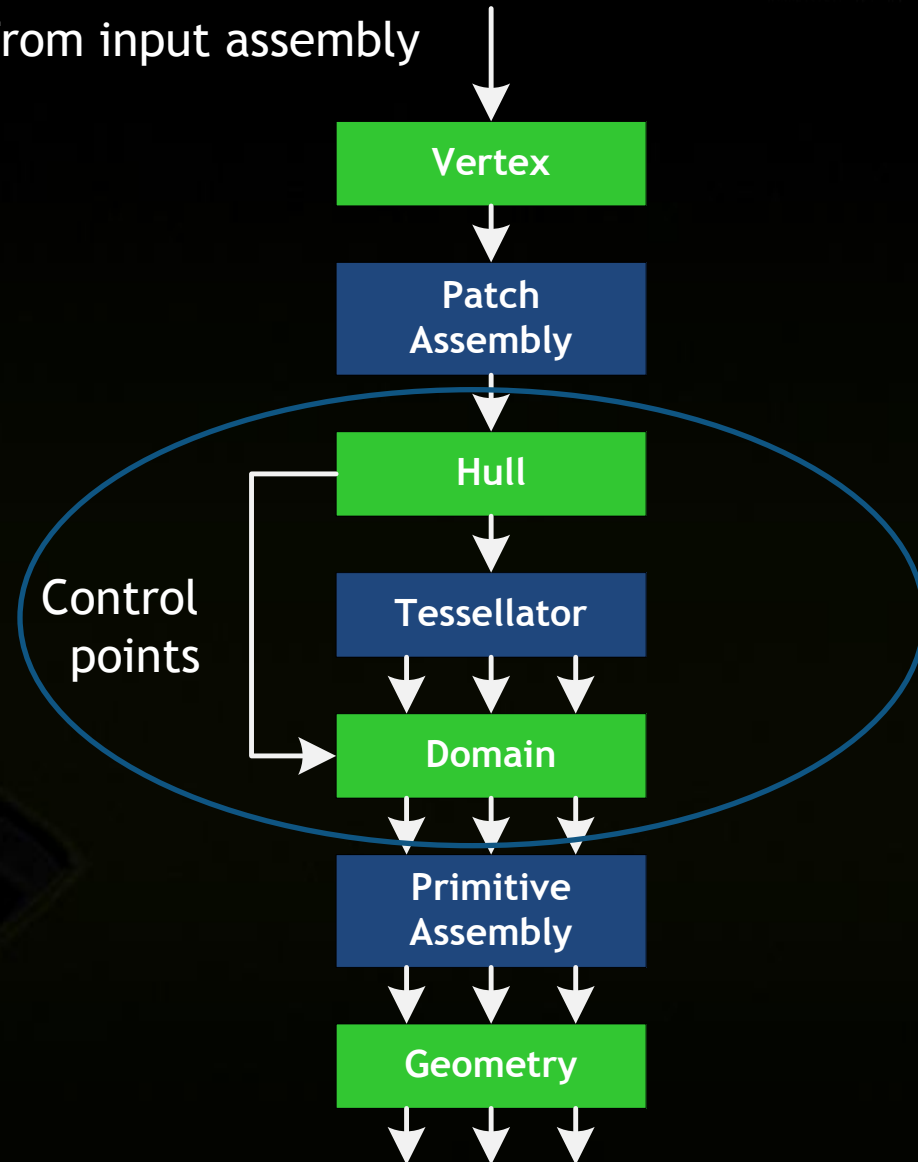

Tessellation in DirectX 11



- **Fixed function tessellation stage**
 - **Configured by LOD output from Hull Shader**
 - **Produces triangles and lines**

From input assembly

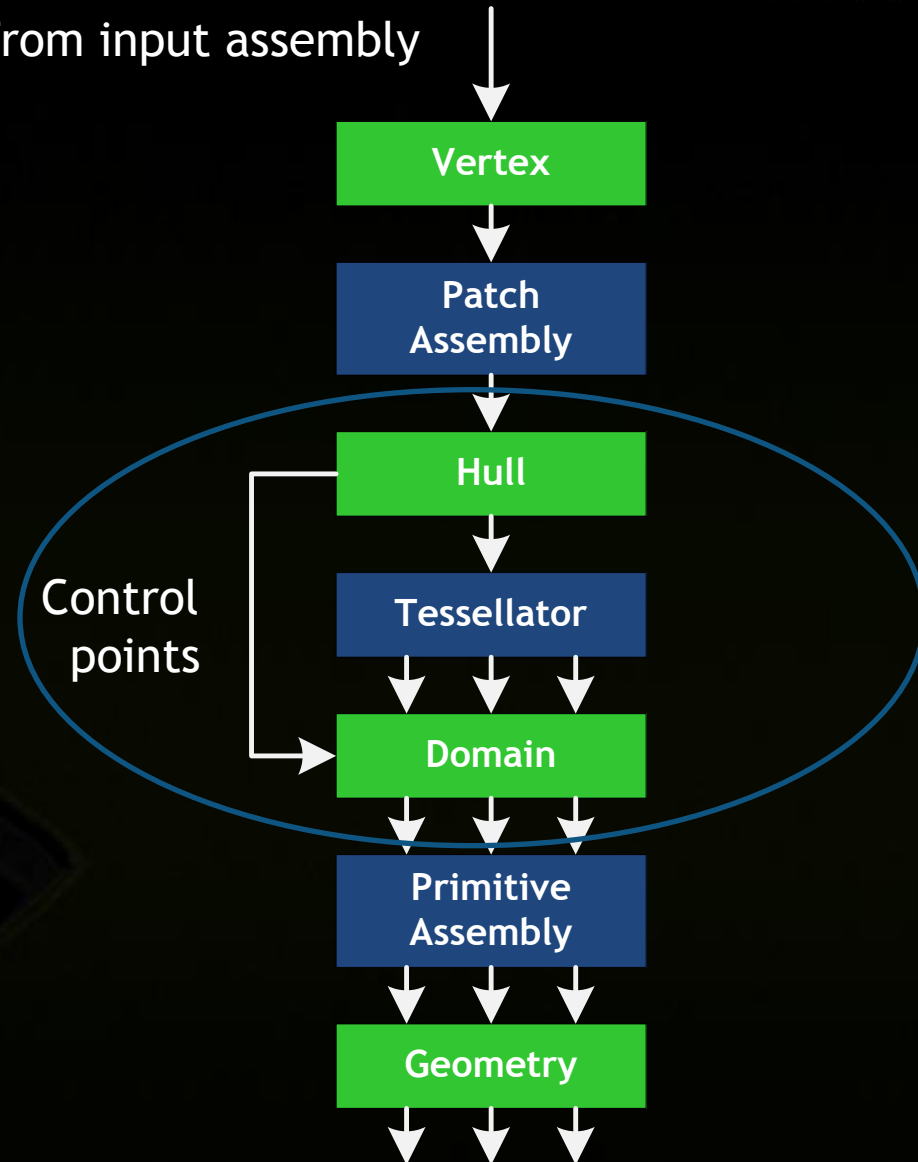

Tessellation in DirectX 11



- **Domain shader**
 - Runs post-expansion
 - Maps (u,v) to (x,y,z,w)
 - Implicitly parallel

From input assembly

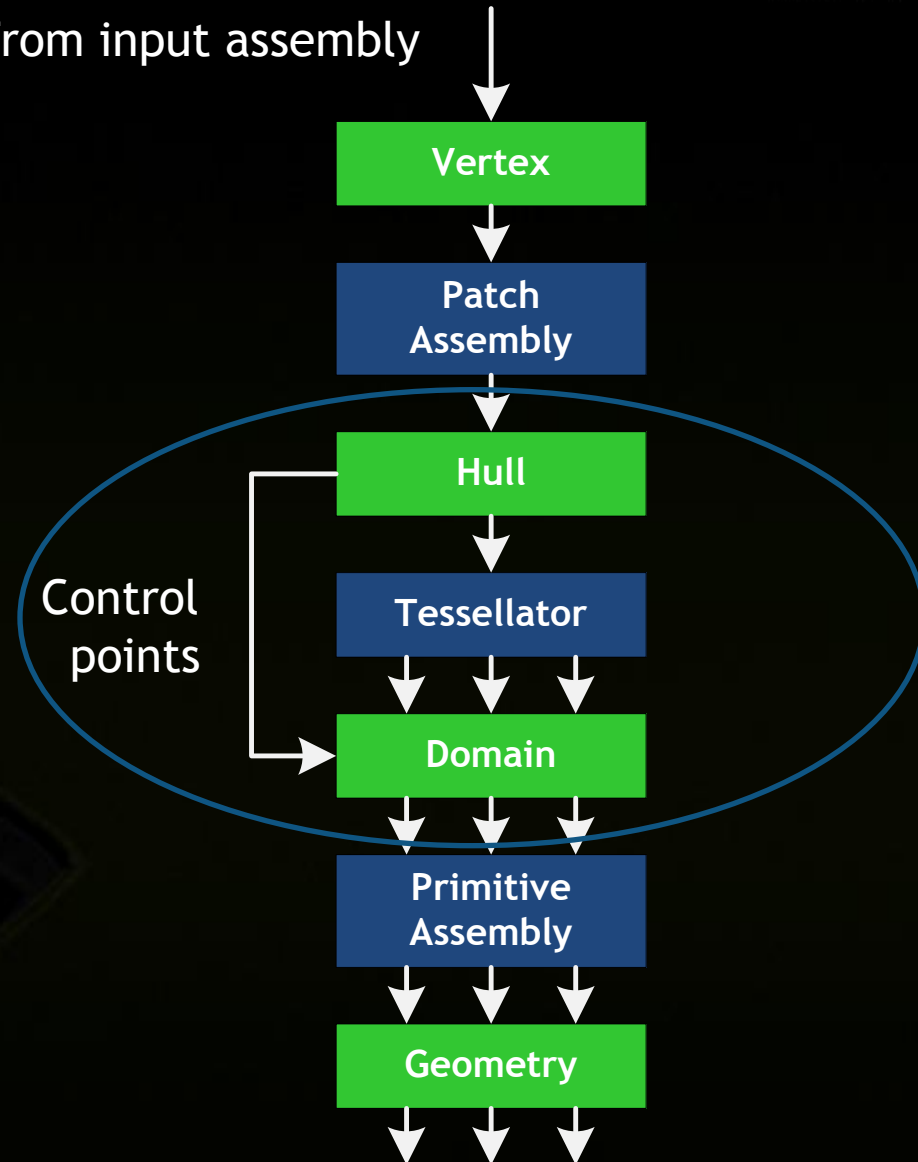

NVIDIA DX10 Logical Pipeline

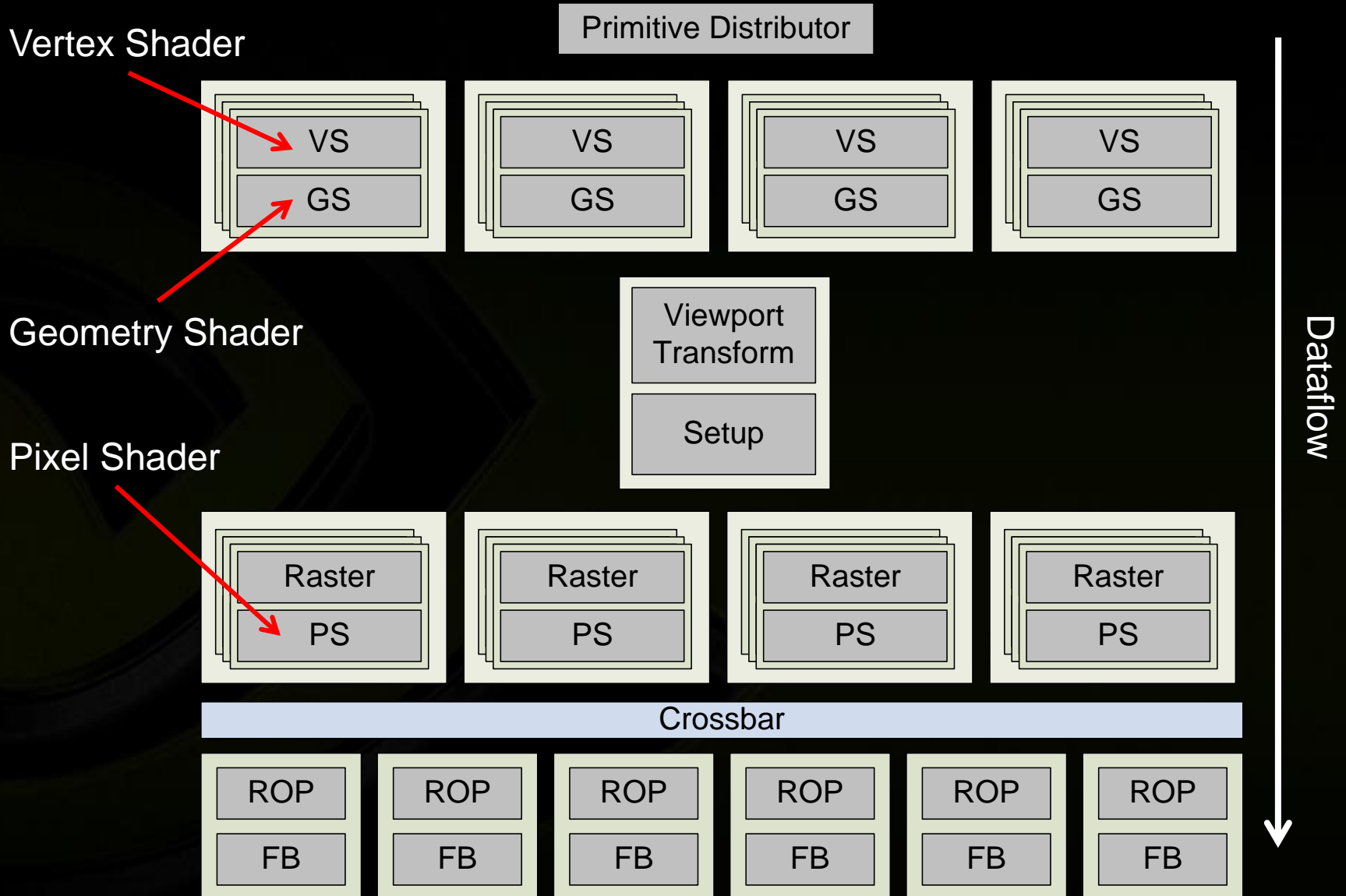

DX10 Logical Pipeline + Tessellation

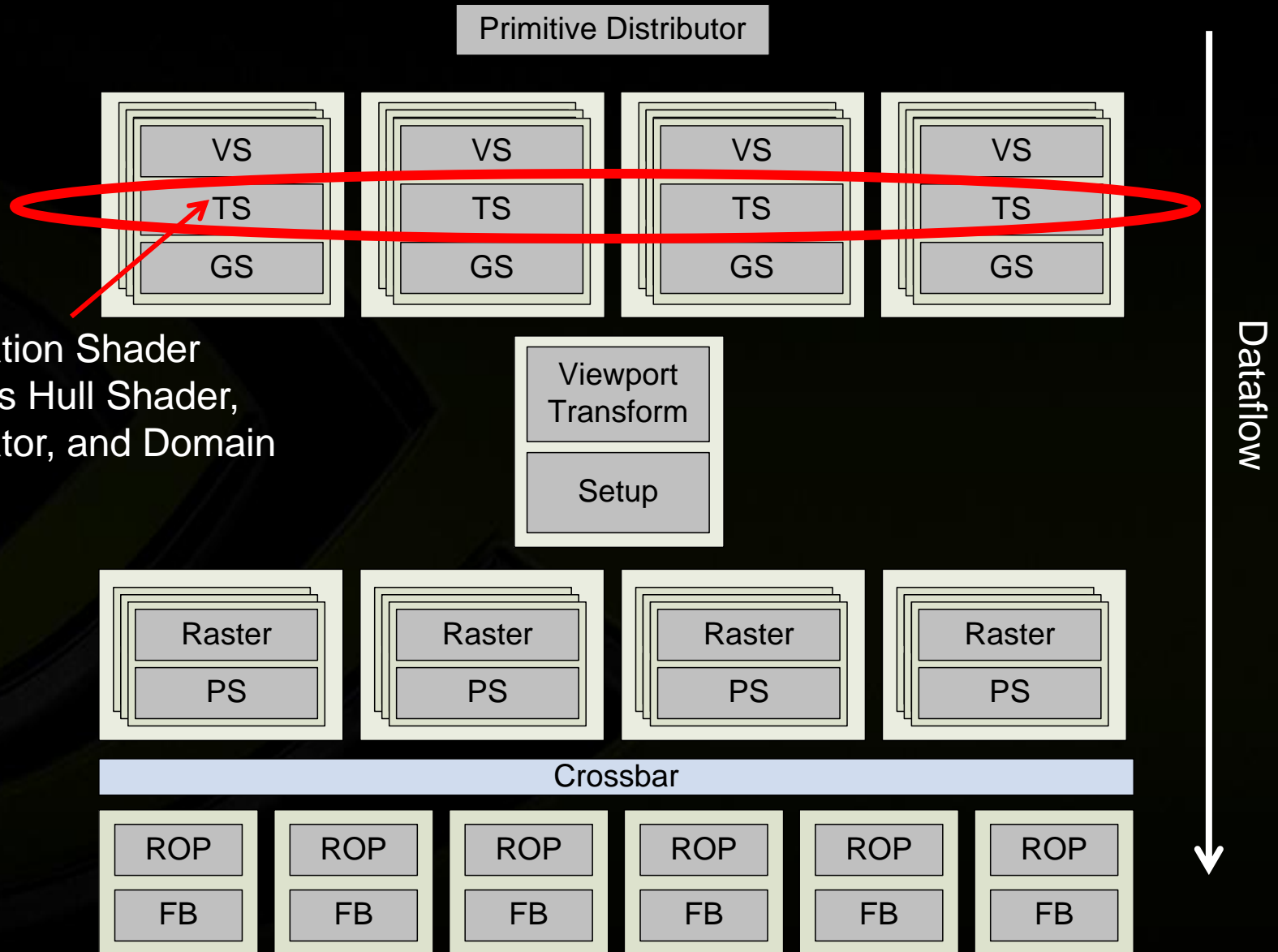

Tessellation Shader
(includes Hull Shader,
Tessellator, and Domain
Shader)

Problems With DX10 + Tess. (1)

- Data expansion in TS can lead to excessive buffering requirements after GS
 - Have to drain GS_0 before GS_1 to maintain API ordering

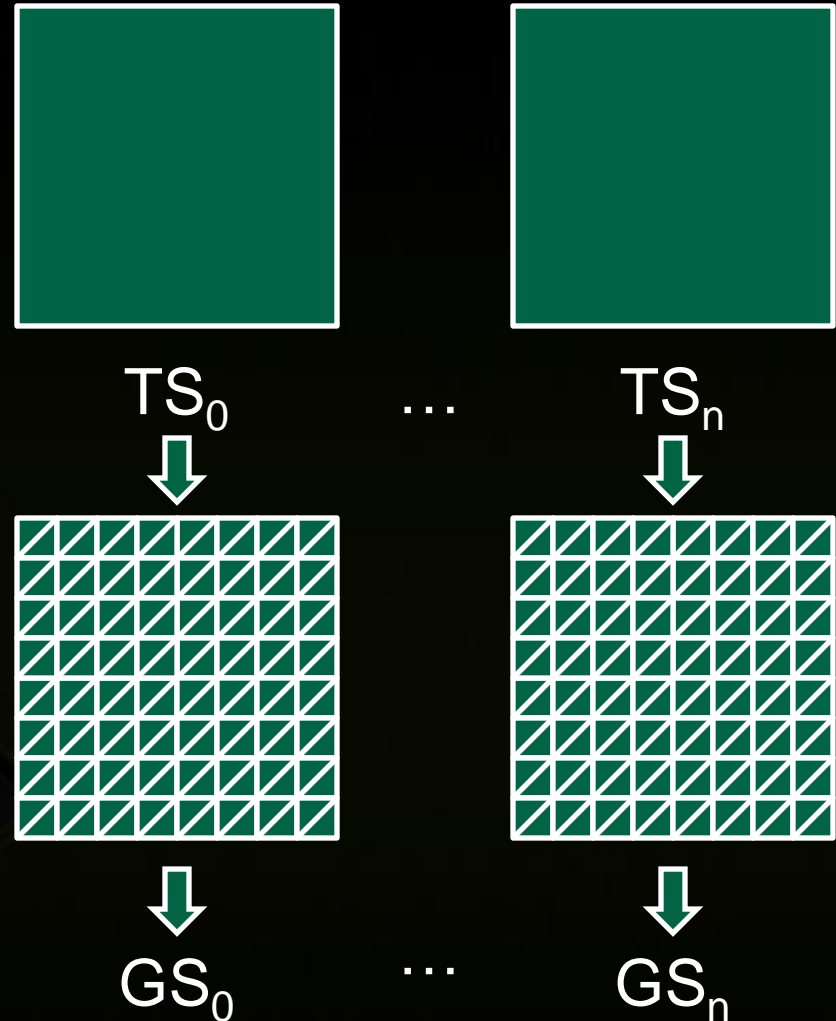

Problems With DX10 + Tess. (2)



- **Setup limited prim rate**
 - Already a problem for CPU-generated geometry
 - Tessellation generates even more primitives

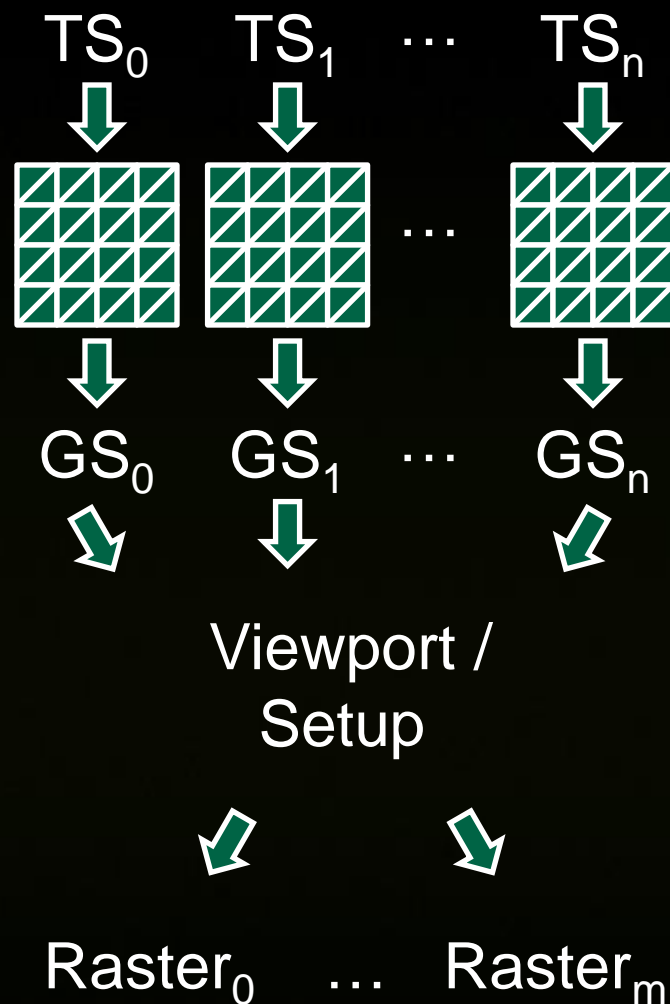

Fermi GF100 Logical Pipeline

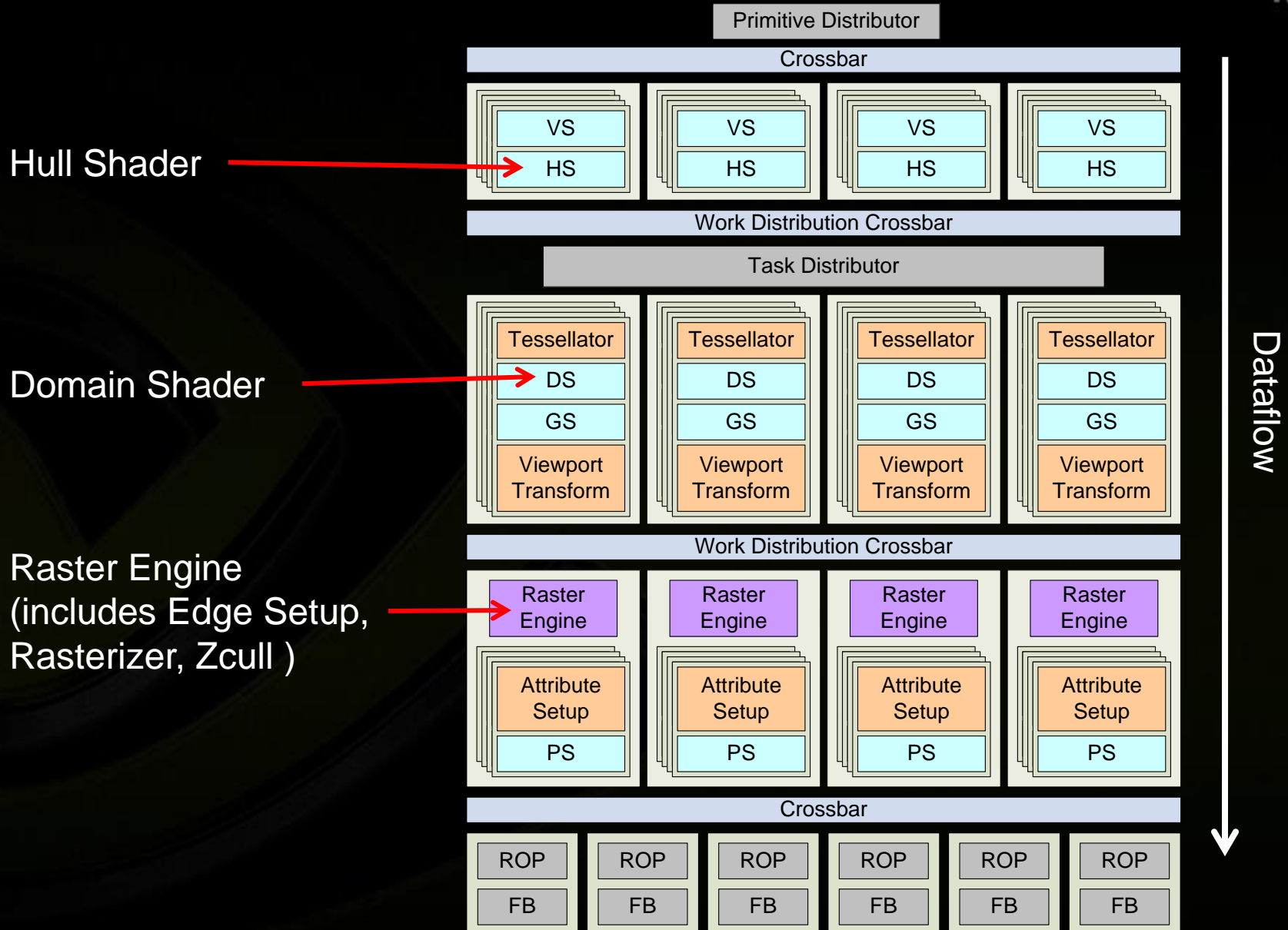

Fermi GF100 Logical Pipeline



Polymorph Engine
(includes Tessellator,
Viewport Transform,
and Attribute Setup)

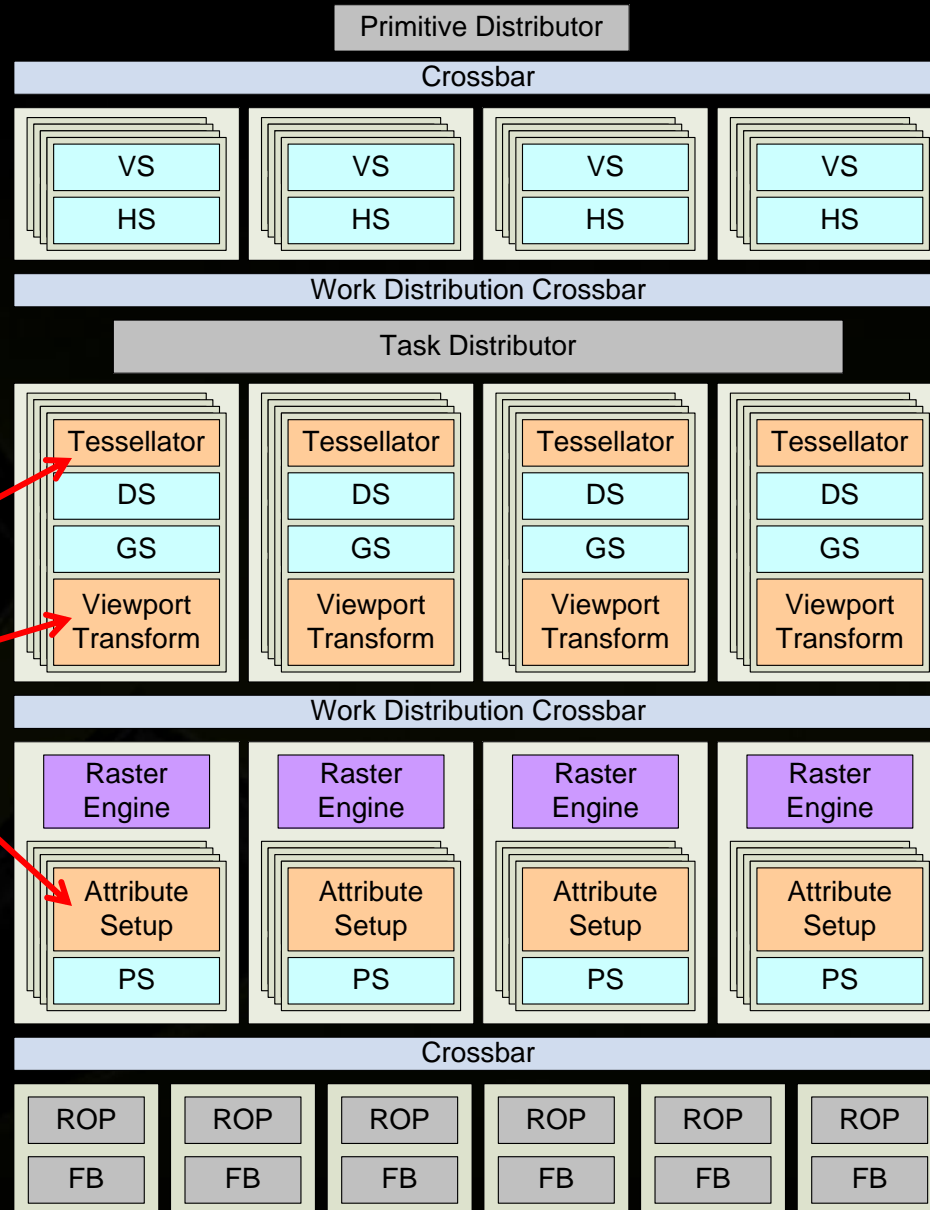

Fermi GF100 Tessellation Features 1



- **Task Distributor**

- Task \approx Hull Shader output
 - Control points plus tessellation factor
 - Pre-expansion
- Distributes tasks for subsequent geometry processing
 - Expand patch into primitives
 - Optional GS
- Reduces buffering requirements

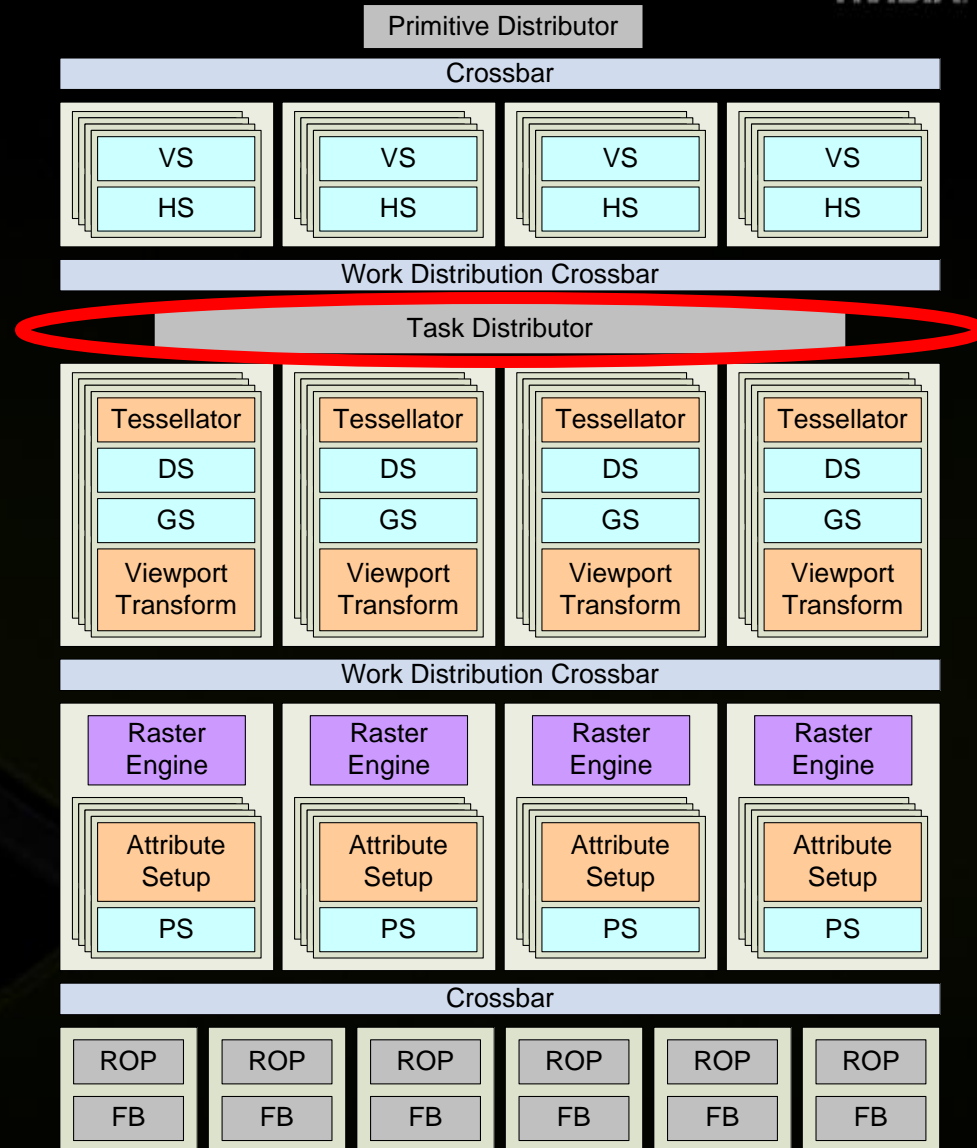

Fermi GF100 Tessellation Features 2



- **Parallel Viewport Transform**
 - Includes clipping and culling
 - Eliminate serialization point

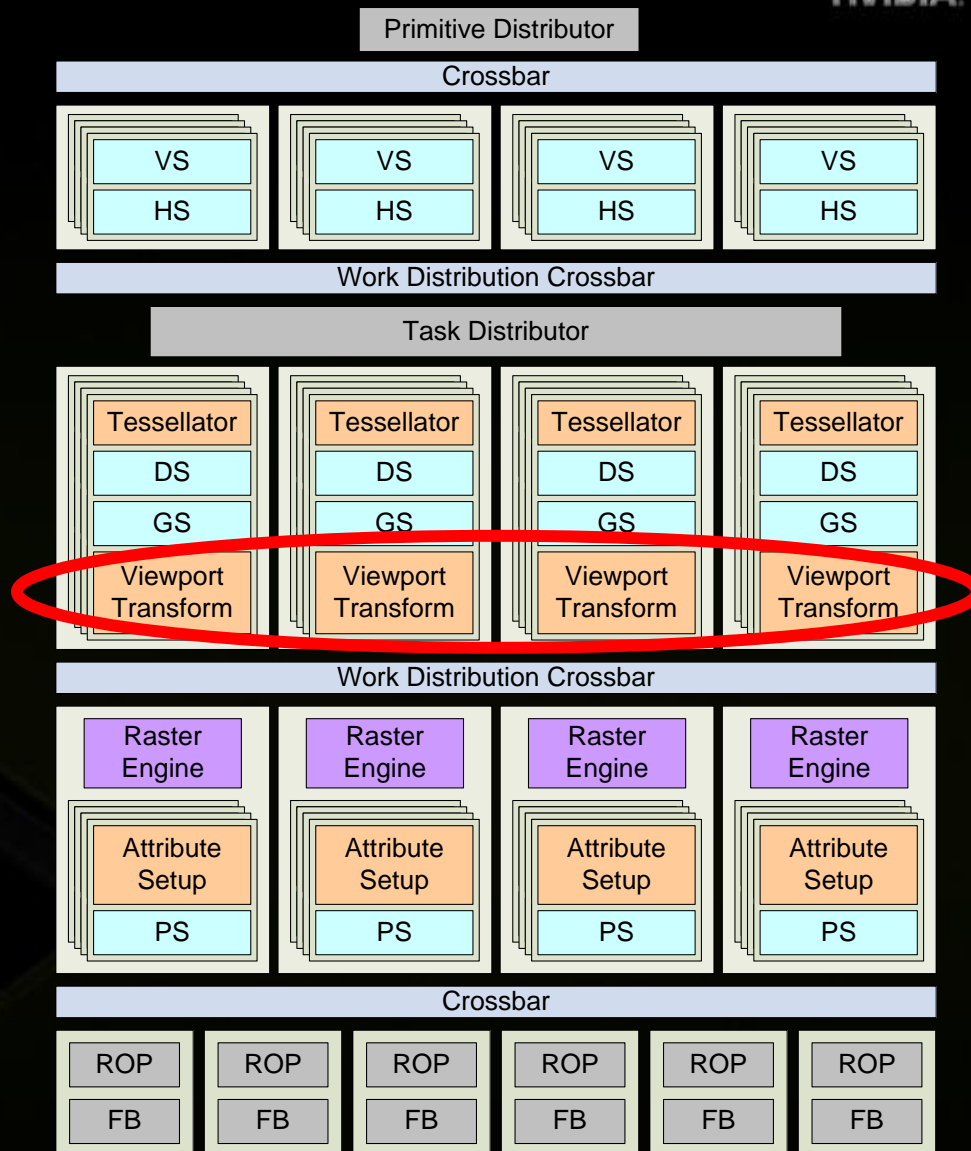

Fermi GF100 Tessellation Features 3



- **Parallel Rasterization**
 - Including Edge Setup, Rasterization, and Zcull
 - Improved primitive throughput
 - Multiple primitives per clock
 - Screen mapped for load balancing

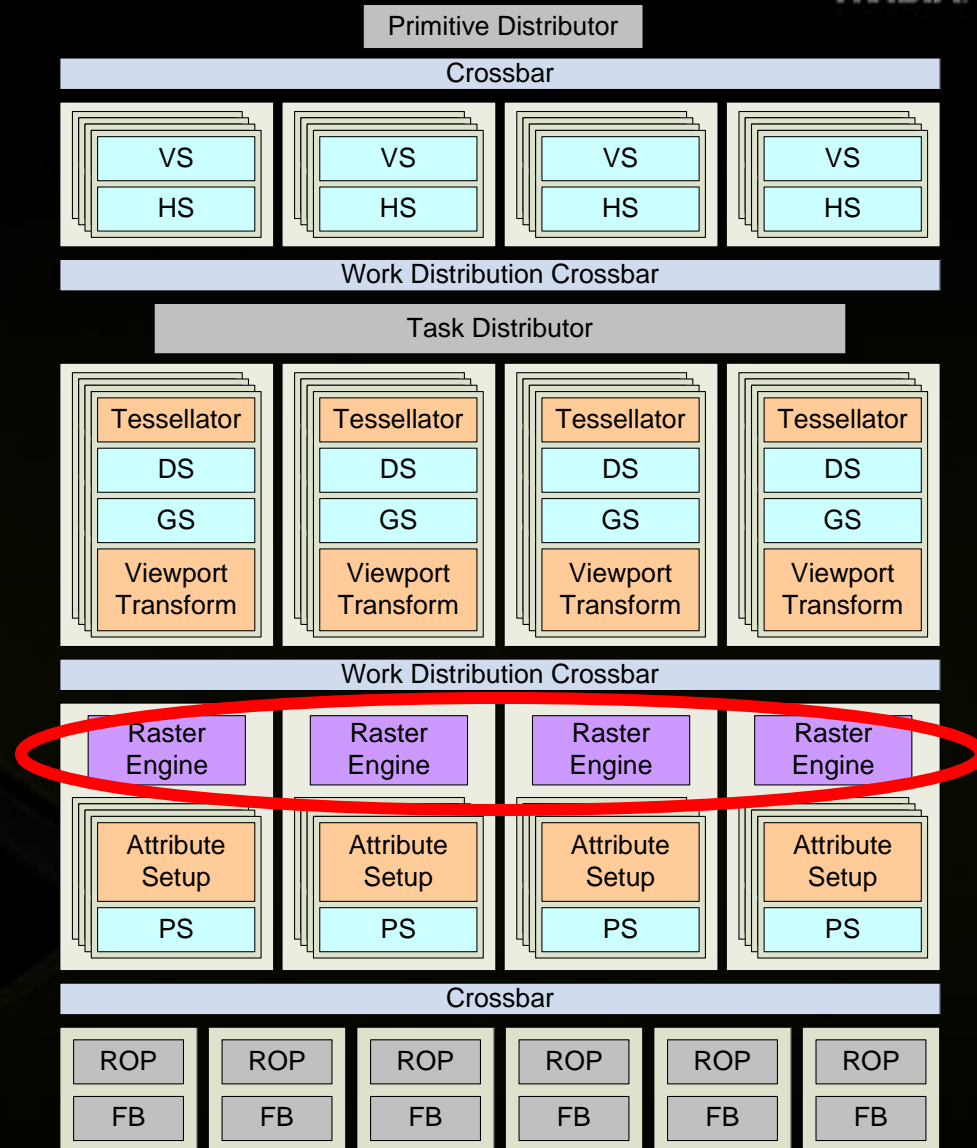

Screen Mapped Rasterization

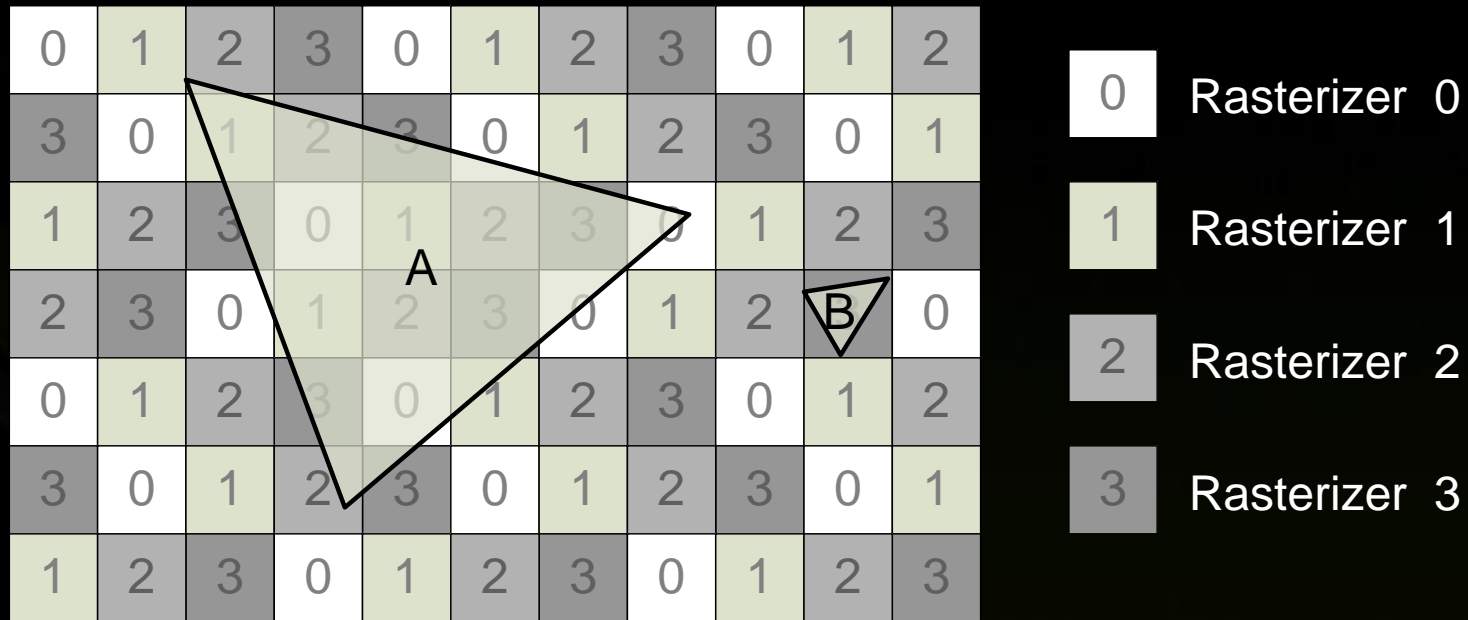

- Each block is a tile of pixels
- Rasterizers uniquely own pixel tiles
- Note: small primitives can overlap multiple tiles

Challenge: Maintaining API Order



- Parallelization is easy
 - Maintaining API ordering is a challenge
- Work Distribution Crossbar (WDX)
 - Similar to Pomegranate [Eldridge et al. 2000]

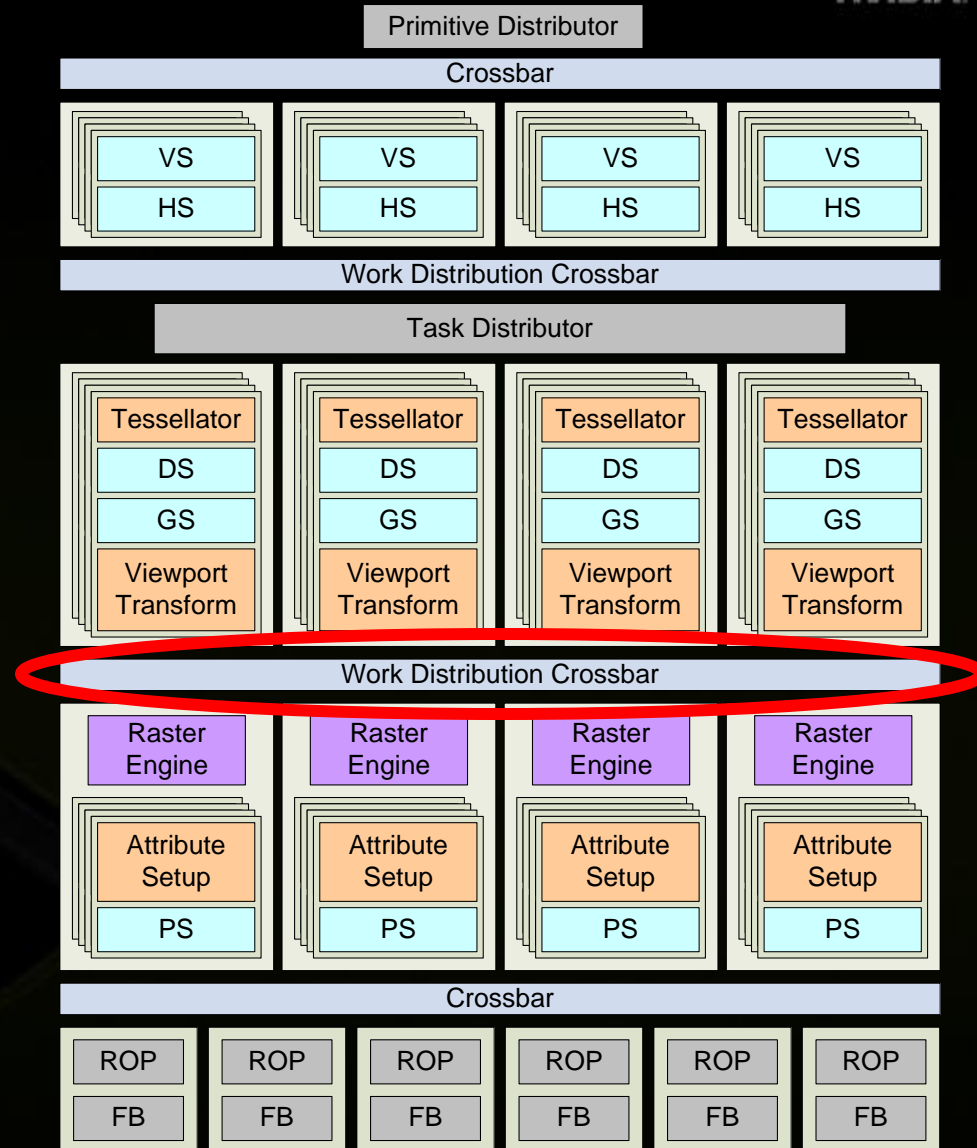

Work Distribution Crossbar



- **OWDX**
 - Uses primitive bounding box to determine which rasterizers get which primitives
- **SWDX**
 - reconstructs API order
- **Rasterizers uniquely own pixels**
 - No subsequent sorting for ordering required

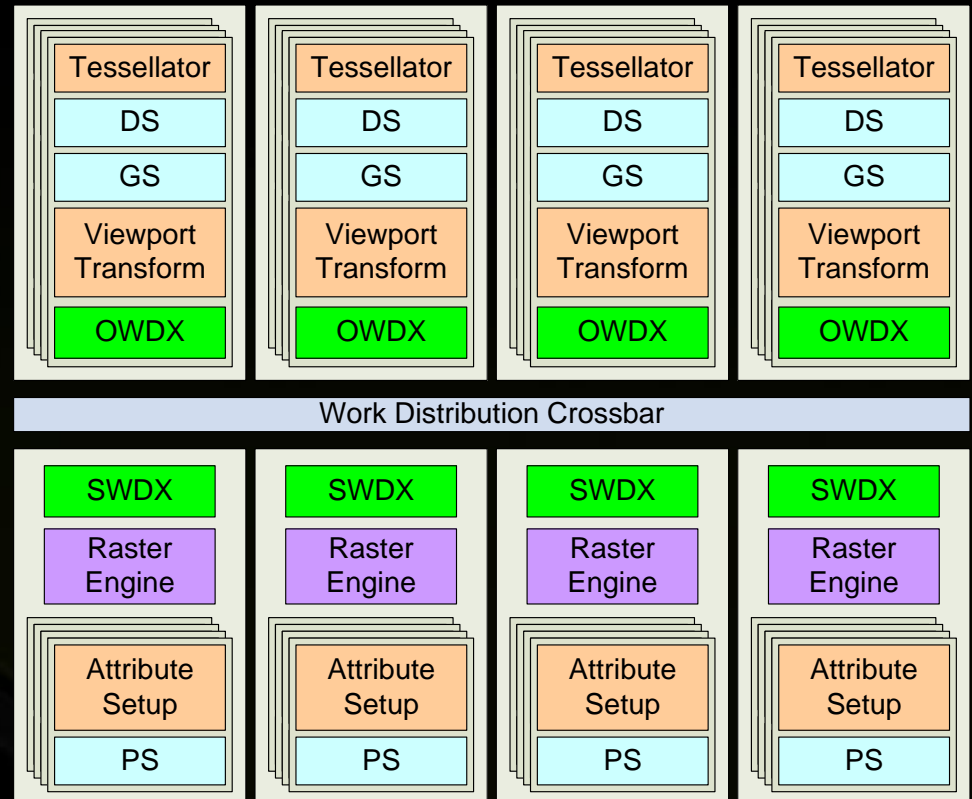

Handling Load Imbalance



- **Load imbalance is a concern for all region-based architectures because they are non adaptive**
 - **Static imbalance**
 - Different screen regions get differing amounts of work
 - Mitigated by relatively small pixel tiles
 - **Dynamic imbalance**
 - Lots of tiny primitives in same screen region at the same time
 - Mitigated by buffering
 - We can only buffer so much...

Results



Historical Triangle Rate

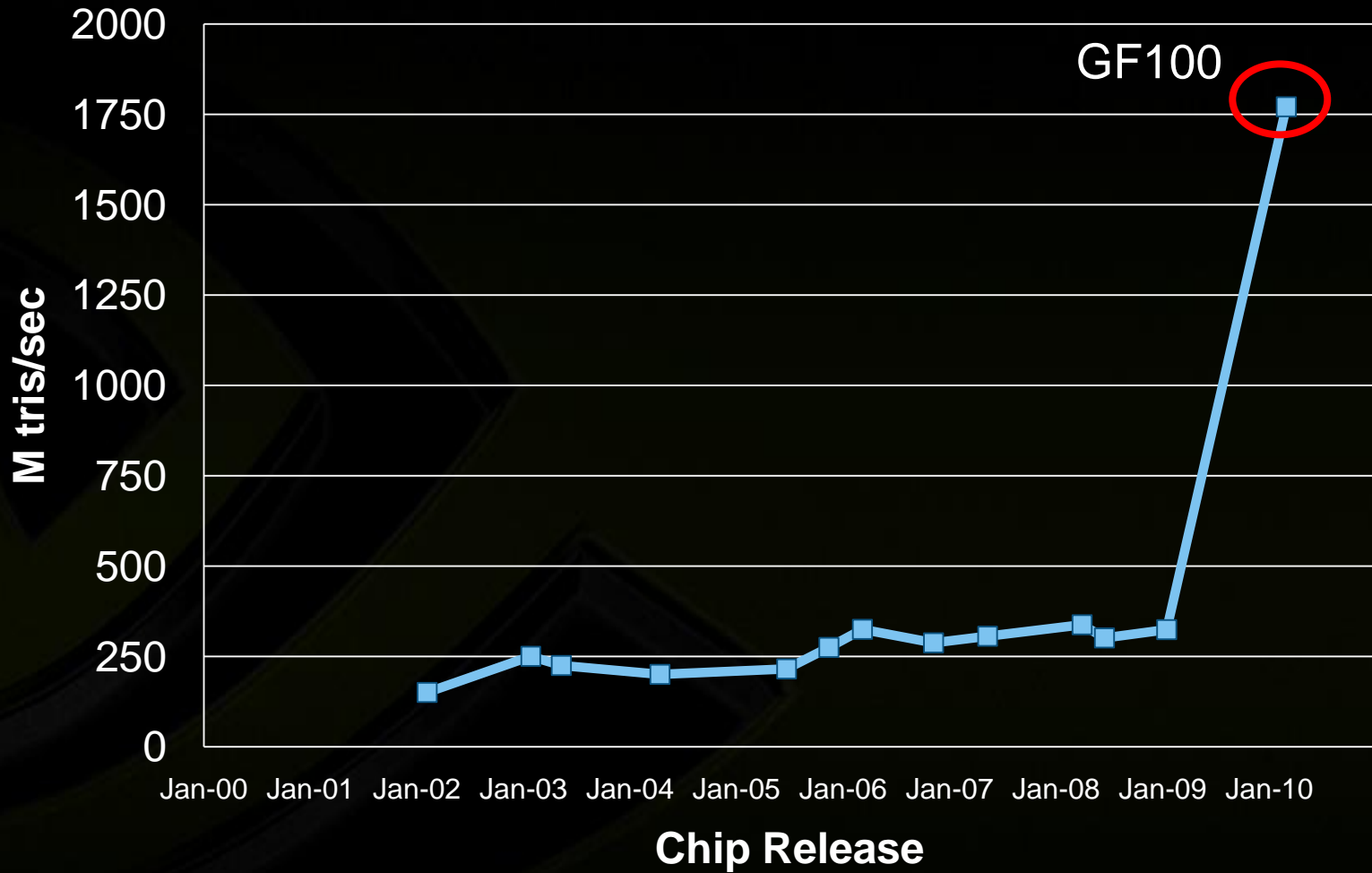

Results – Synthetic Performance Test

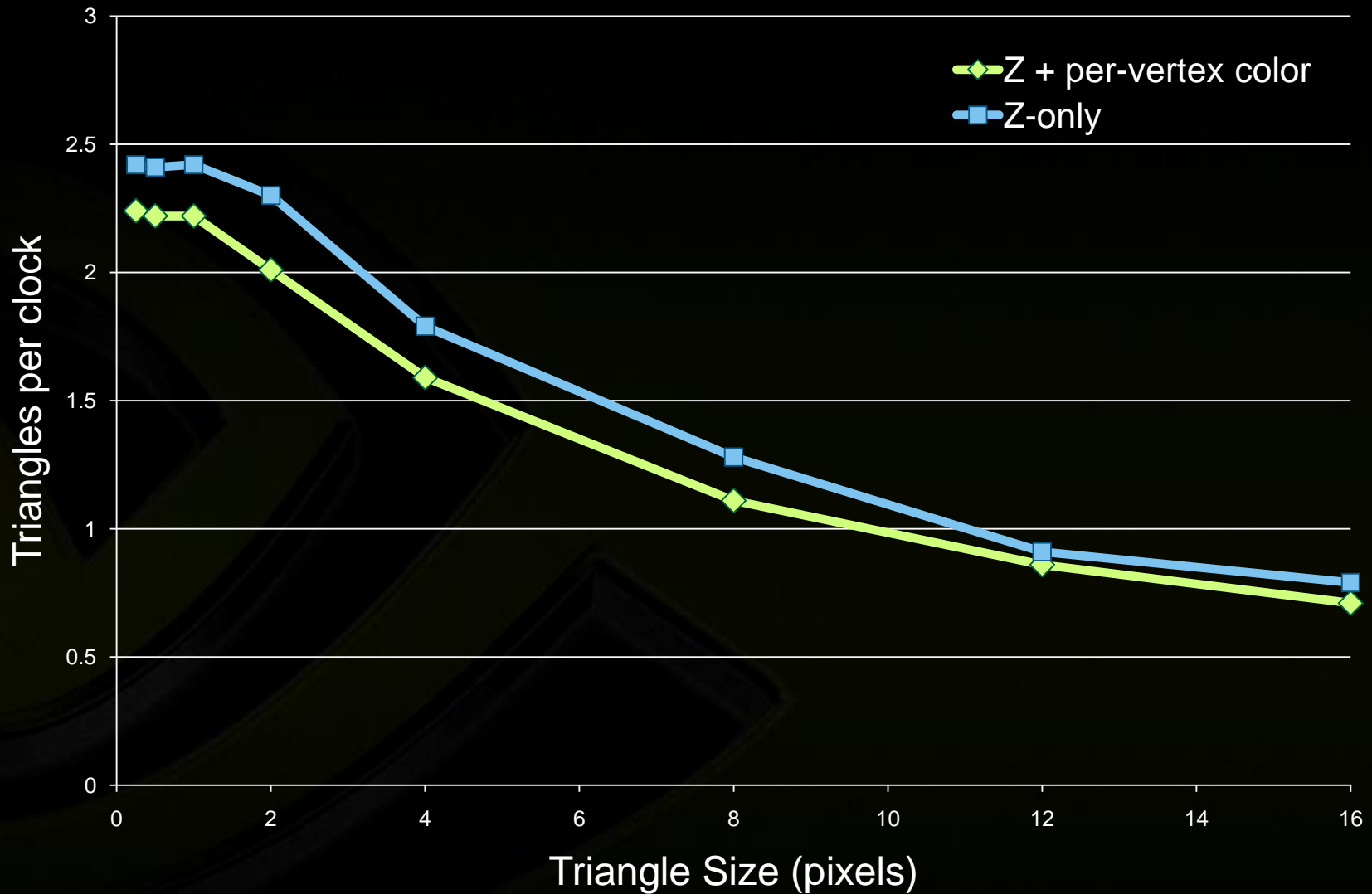

Results – Island Demo

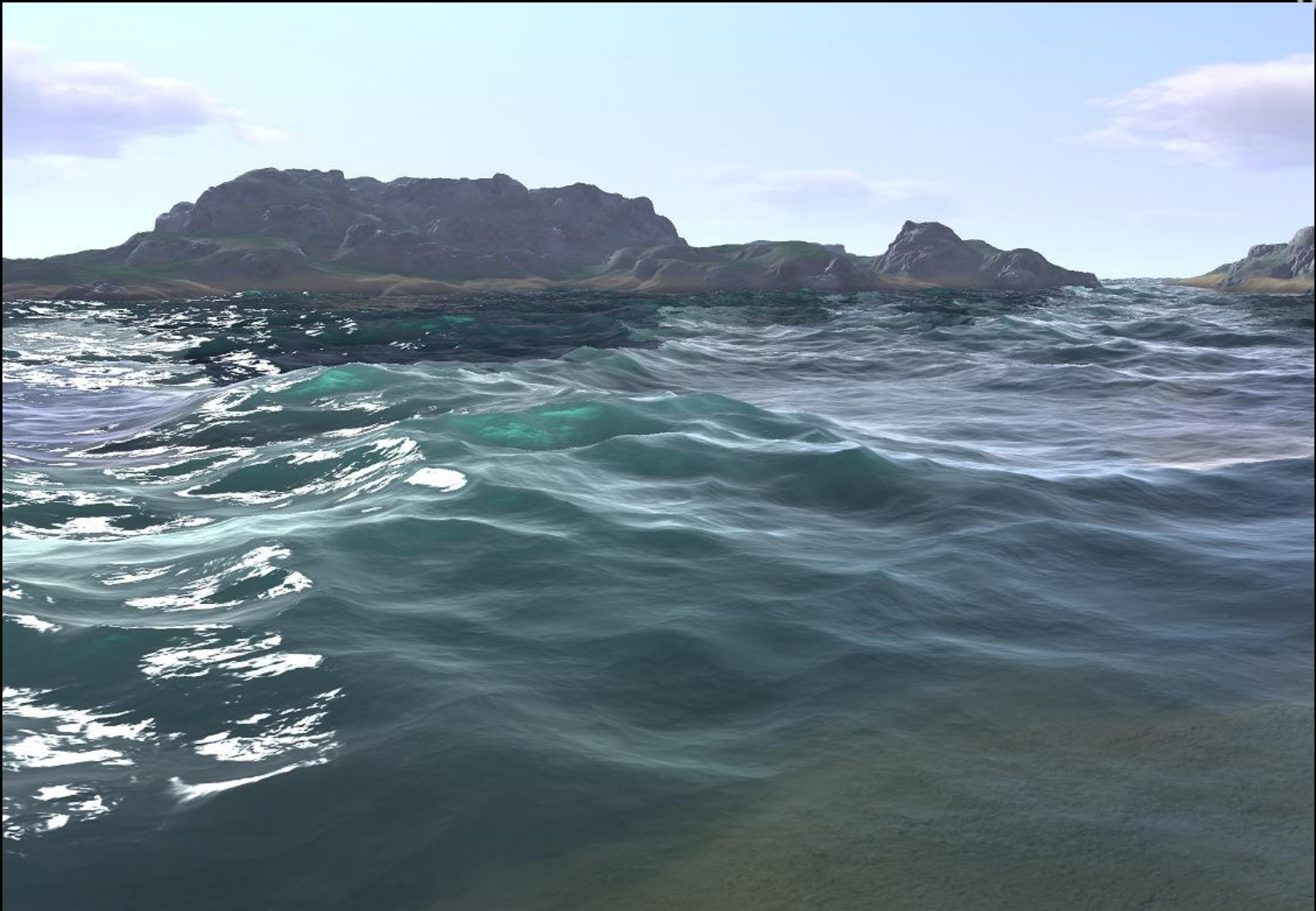

Frame average of 1.94 triangles per clock

Results – Unigine Heaven



2.34 triangles per clock in highly tessellated areas

Demo Time



Summary



- **Tessellation**
 - **Increases geometric realism without burdening the CPU**
- **Fermi GF100 is designed for tessellation**
 - **Eliminates serialization points**
 - **Dramatically improved primitive throughput**
 - **Next-generation visual fidelity**

Acknowledgements



- **Steve Molnar**
- **Ziyad Hakura**
- **Andreas Dietrich (demo help)**
- **Entire Fermi GF100 team**

Questions?

